



OBSERVATIONAL ASTRONOMY

AUTUMN 2024

Lecture 7

Vitaly Neustroev

297

Infrared Detectors

Photoconductors

Bolometers

Infrared Passbands

298

Infrared passbands are determined by the windows of transparency of the atmosphere.

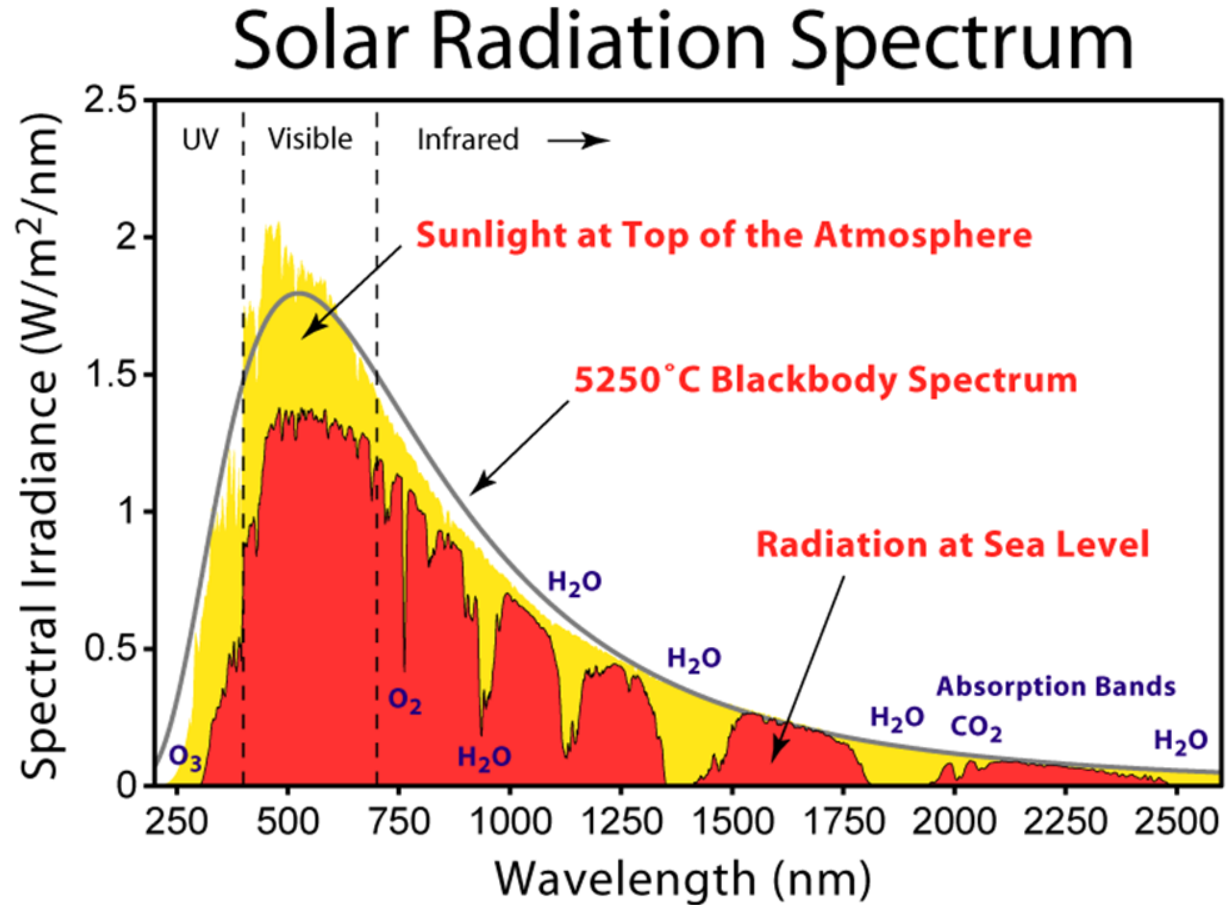

Infrared ranges and IR detectors

299

- The infrared region is divided into three wavelength ranges:
 - ▣ the near-infrared (NIR): 0.7-5 μm
 - ▣ the mid-infrared (MIR): 5-30 μm
 - ▣ the far infrared (FIR): 30-1000 μm

- Many of the detectors considered above have some infrared sensitivity, especially up to 1 μm .

- At longer wavelengths other types of detectors are needed.

Infrared Array detectors (1)

300

$$\lambda [\text{\AA}] = 12.40/E [\text{keV}]$$

- Infrared semiconductor detectors cannot be made from silicon any more as the band gap is too large: **the band gap of silicon is 1.1 eV and the critical wavelength is 1.1 microns**. Radiation of longer wavelength cannot excite electrons from the valence band to the conduction band in silicon. Materials with smaller band gaps and longer critical wavelengths should be used.
- **Germanium** can be used at the shortest wavelengths, but **Indium Antimonide** and **Mercury Cadmium Telluride** are more widely used.
- People have tried making CCDs out of Indium Antimonide, but with no significant success.

Infrared Array detectors (2)

301

- There are two main types of IR detectors:
 - ▣ For the NIR and MIR and somewhat into the FIR — **the photoconductor**. In such detectors **individual photons create free charge carriers**. Typical IR detectors are classified as **photovoltaic** or **photoconductive**, according to whether they register photons by generating a current of electrons or merely by changing their resistance.
 - ▣ For the FIR — **the bolometers**, in which photons are absorbed and thermalized.

Photovoltaic detectors

302

- Single pixel infra-red detectors have long used the **photovoltaic** effect.
- Detectors are made of semiconductors and rely on the excitation of electrons from an energy band in which they are immobile (the valence band) to the conduction band, where they are free to move about.
- p-n junction generates an internal electric field to separate the photon generated electron-hole pairs.
- Migration of holes and electrons changes the electric field, hence there is a voltage change across the junction which can be measured.

Photoconductive Cells

303

- Exhibit a change in **conductivity** with the intensity of their illumination.
- The mechanism is the absorption of the radiation by the electrons in the valence band of a semiconductor and their consequent elevation to the conduction band.
- The conductivity increases with increasing illumination, and is monitored by a small bias current.
- There is a cut-off point determined the minimum energy required to excite a valence electron over the band gap (also correct for photovoltaic detectors).

Infrared Detectors: limitations

304

- The smaller the bandgap, the more likely electrons are to enter the conduction band unwanted, by thermal excitation. It is therefore necessary to cool these longer-wavelength detectors more than the shorter-wavelength ones.
- The longer wavelength the colder the required temperature:
 - ▣ in the NIR – 77 K (liquid nitrogen);
 - ▣ in the MIR – 4 K (liquid helium);
 - ▣ in the FIR – down to 100 mK are used.

Hybrid Arrays (1)

305

- Modern IR arrays are hybrid arrays, formed of a sandwich of three layers.
- Top layer (assuming radiation is coming down) is an **Indium Antimonide** or **Mercury Cadmium Telluride**, doped to act as a photovoltaic detector.
- Bottom layer is a silicon multiplexer (**amplifier**).

It can be constructed using conventional Si-based techniques, but more often an array of tiny MOSFET (Metal Oxide Semiconductor Field effect Transistor) amplifiers used.

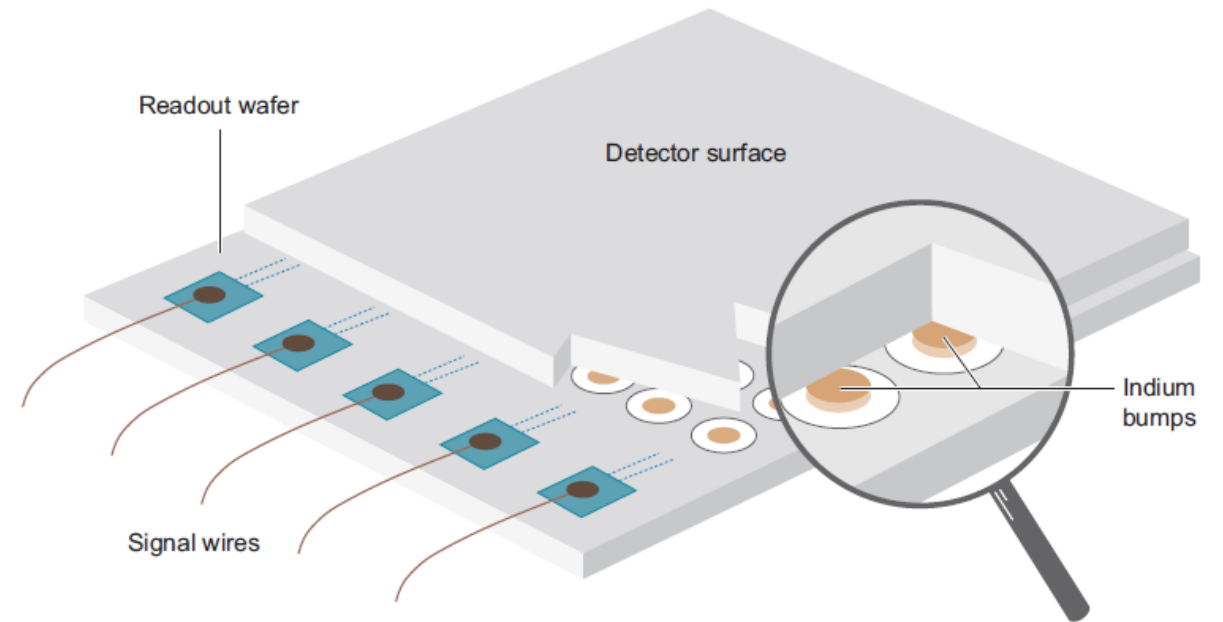

- The two parts are joined electrically with one connection for each pixel.

Hybrid Arrays (2)

306

- In between two layers are Indium bump bonds providing an electrical connection between locations on the IR detector and the elements of the silicon multiplexer.

Indium is a good conductor which is soft even at low temperature, so the device does not crack when cooled.

- Gaps between the indium bonds are filled with epoxy resin to provide mechanical stability.

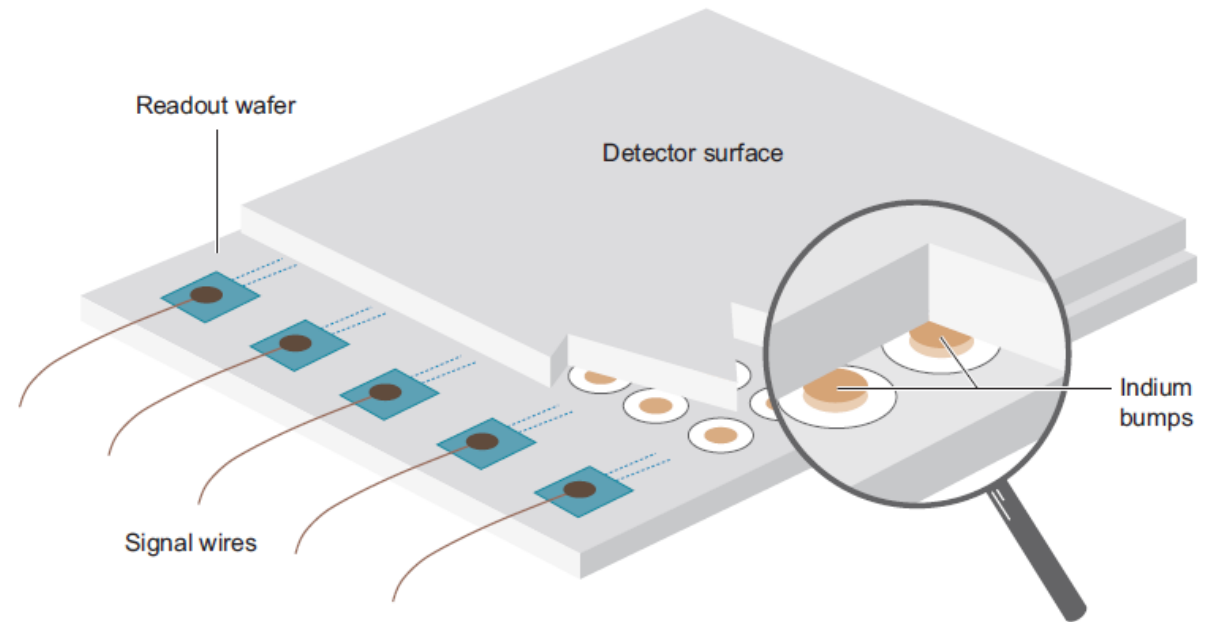

Infrared arrays (1)

307

- Indium Antimonide and Mercury Cadmium Telluride arrays are available in 1024 square formats, maybe 2048 square.
- Quantum efficiency 60% - 80%
- Noise 40 electrons/pixel
- Cost ~ €300,000 per array!

Infrared arrays (2)

Original
64x64

256x256

1024x1024

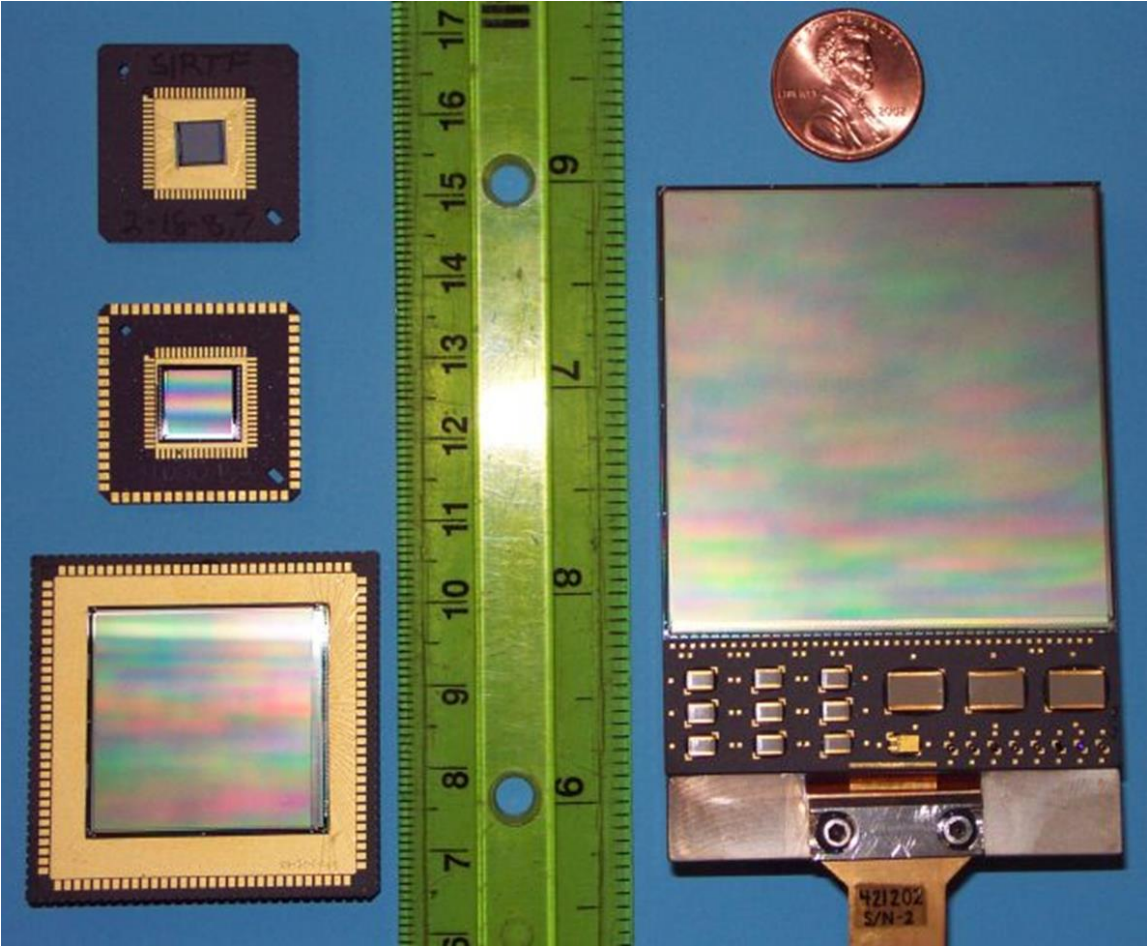

2048x2048

Bolometers (1)

309

- Bolometers operate on a different principle from the detectors discussed before.
- Rather than individual photons creating free charge carriers, photons are absorbed and thermalized, and the resulting energy is sensed.
- This approach yields very high performance detectors for the submillimeter and millimeter spectral regions.

Bolometers (2)

310

- Photons incident on the absorber raise its temperature, causing a sensitive thermometer attached to it to change resistance, producing a signal that can be amplified to achieve a detection.
- Bolometers must be operated at low temperatures to suppress thermal noise that arises as a result of thermodynamic fluctuations in the flow of energy across the thermal link.

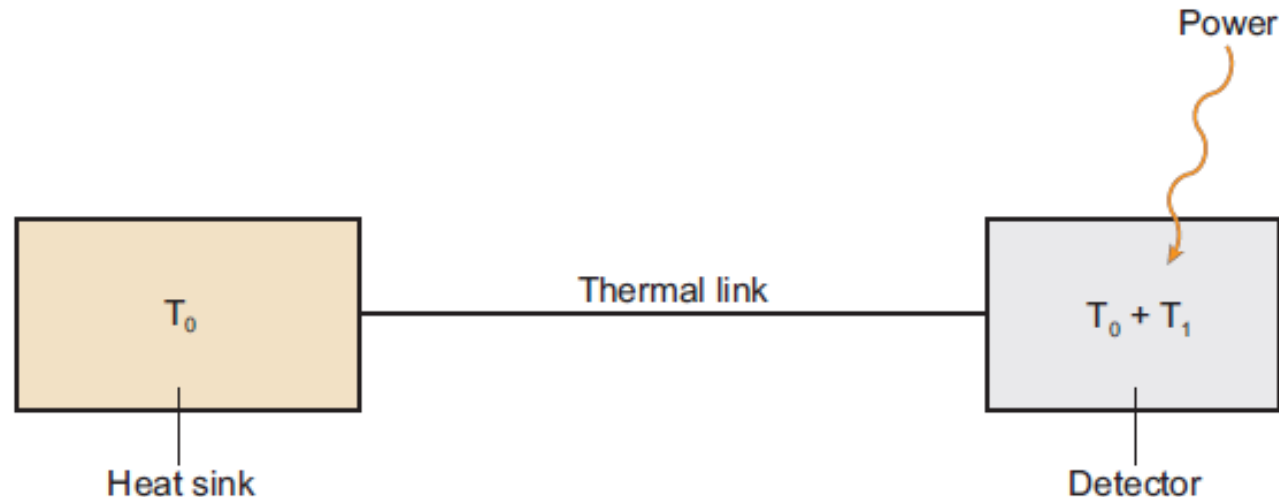

Components of a Bolometer

311

Self reading material

- Absorber with heat capacity C
- Thermometer with resistance R , which is usually some device whose resistance changes as a function of temperature
- Heat sink held at fixed temperature T_0
- “Weak Link” – small thermal conductance G between absorber and heat sink.
- Load resistor R_L
- Constant current power supply. generating bias current I
- Device to measure voltage changes

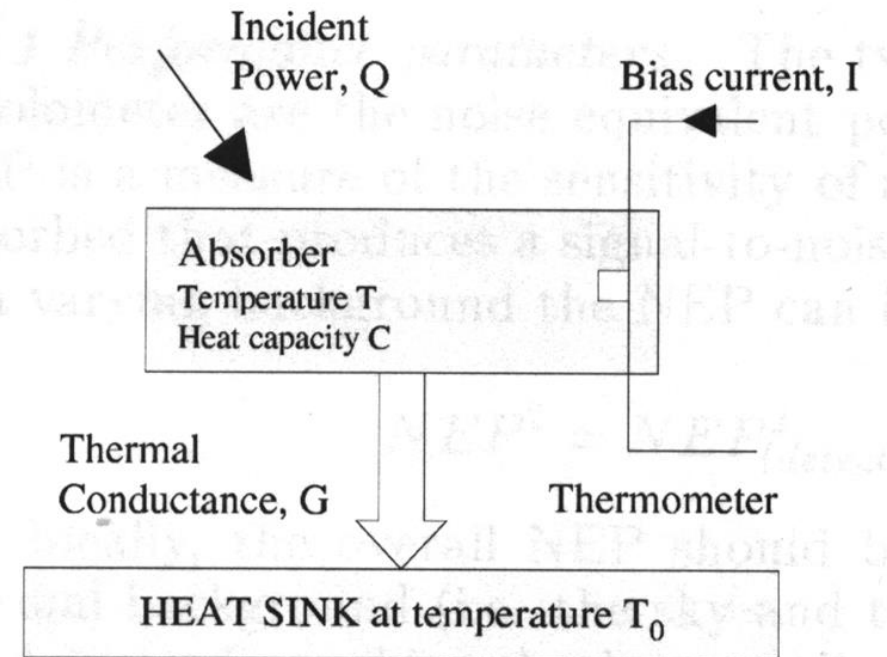

Noise Equivalent Power (NEP)

312

Self reading material

- The Noise Equivalent Power (NEP) is a measure of the sensitivity of the bolometer, and is defined as the power absorbed which produces a signal-to-noise of unity at the output.
- Units are $\text{Watts/Hz}^{0.5}$

Components of the Bolometer NEP

313

Self reading material

- **Johnson noise** – due to the random motions of the electrons in the thermometer:

$$NEP_j^2 = 4 k T R / S^2$$

where S is the responsivity of the device, and gives the output power per unit input voltage, in Volts per Watt.
 k is Boltzmann's constant

- **Phonon noise** – due to quantization of the phonons which transport energy between the absorber and the heat sink along the thermal conductance G .

$$NEP_p^2 = 4 k T^2 G$$

Components of the Bolometer NEP

314

Self reading material

□ Johnson noise:

$$\text{NEP}_j^2 = 4 k T R / S^2$$

□ Phonon noise:

$$\text{NEP}_p^2 = 4 k T^2 G$$

So to **minimize** the detector noise we need to **minimize** **R**, **T**, **G** and **maximize** **S**.

Components of the Bolometer NEP

315

Self reading material

- However, the time constant of the system is:

$$\tau = C / G$$

- If the time constant is long then time variability of the background dominates over the noise sources, so the choice of G is a tradeoff between lowering the NEP and the response time.
- Temperature coefficient of resistance is given by:

$$\alpha = (T/R)(dR/dT)$$

The responsivity of the device depends upon α . For a typical semiconductor bolometer $\alpha \approx 5 - 10$.

Semiconductor bolometers

316

- Most bolometers incorporate a semiconductor resistance thermometer, and a metal coated dielectric as the absorber.

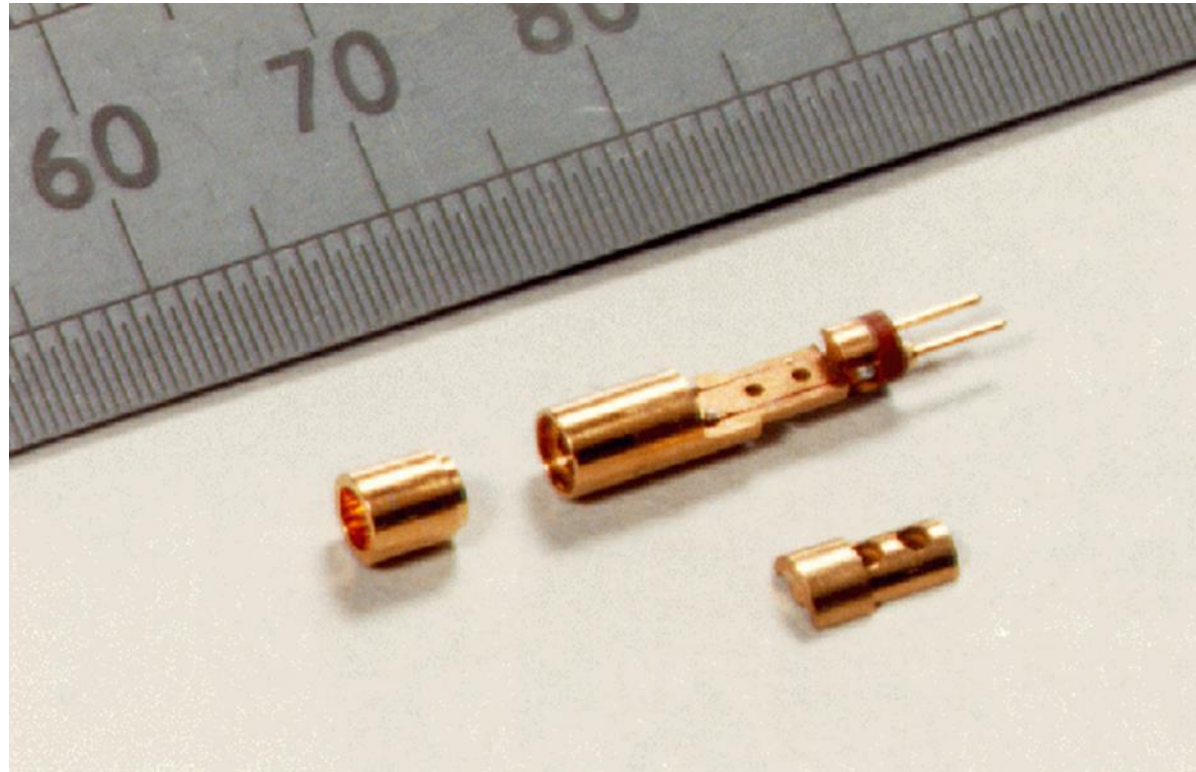

Bolometer Arrays

